



1

Formel 1 var bättre
förr, eller i varje fall
snyggare...
– Märke?

1. *Aston Martin*
- X. *BRM*
2. *Vanwall*





I vilken av Povel Ramels
filmer förekommer Yngve
Gamlin som den ryske
Demondirigenten
Olja Schlaskokowitsch?

1. *I rök och dans*
- X. *I dur och skur*
2. *Ratataa*



Den här mycket framgångsrika 1.6-litersmotorn hade beteckningen FVA. Vad står bokstäverna för?

1. *!Ford Very Advanced*
- X. *!Four Valves type A*
2. *!For Vanderwell Also*

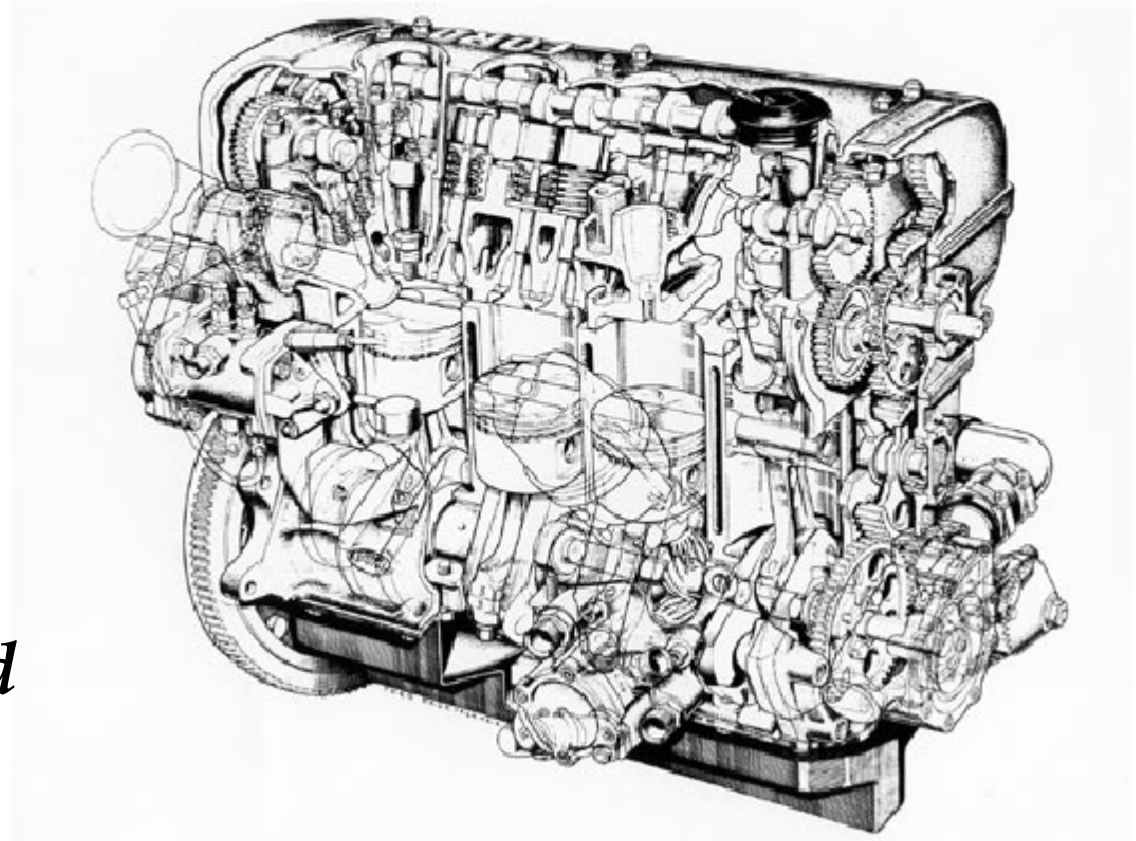



4

Tvåtaktsdiesel, motgående kolvar, en vevaxel, vipparmar, Roots blåsmaskin...
Vilken farkost drevs av denna udda motor?

1.



X.



2.

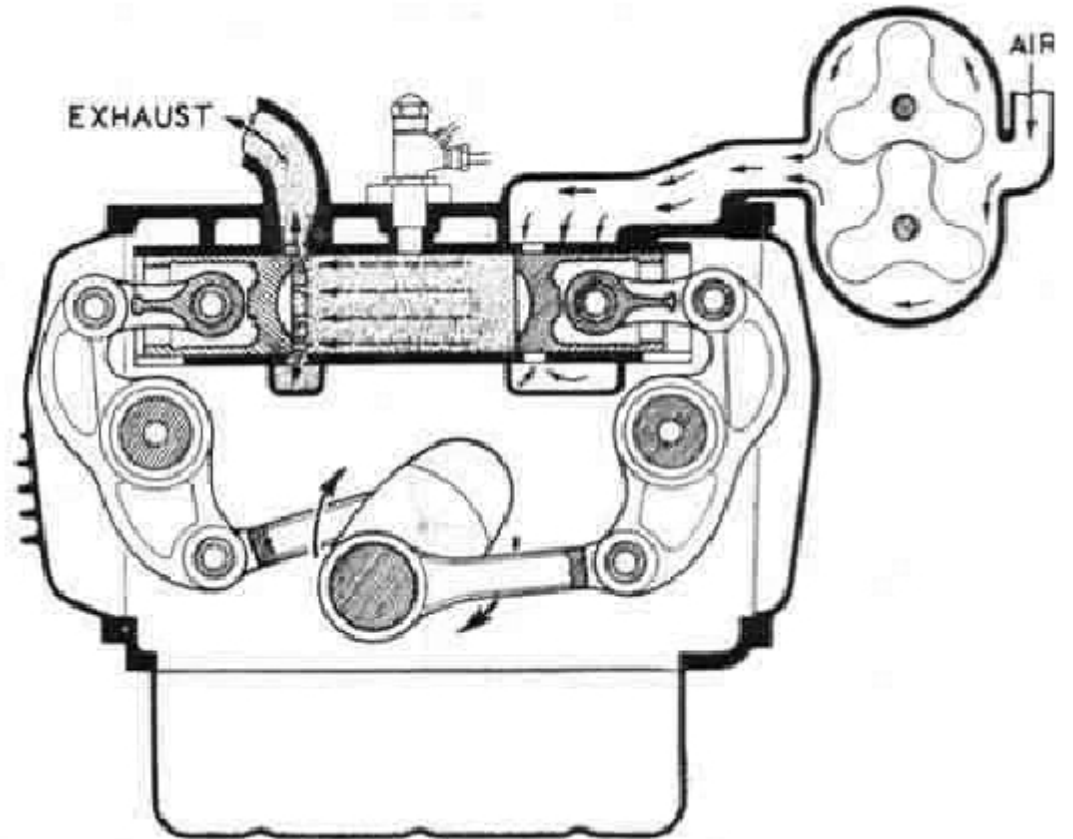



5

Vem är detta?

1. *Fats Waller*
- X. *Fats Domino*
2. *Archie Goodwin*



Ovanlig motorcykel...
Vilket märke?

1. *Benelli*
- X. *Maserati*
2. *Rumi*





Hewland baserade sina tidiga formelbilsväxellådor på VW:s transmission. Med motorn framför lådan skulle det ge 4 växlar bakåt, 1 framåt. Hur löste man detta dilemma?

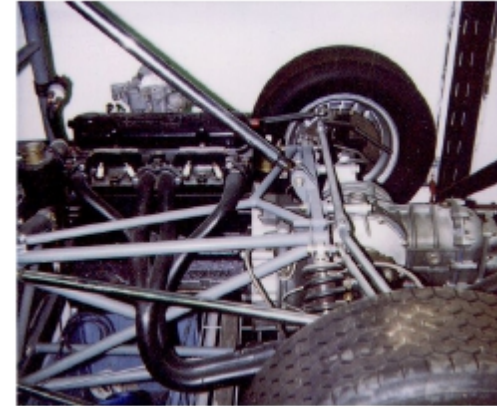

7

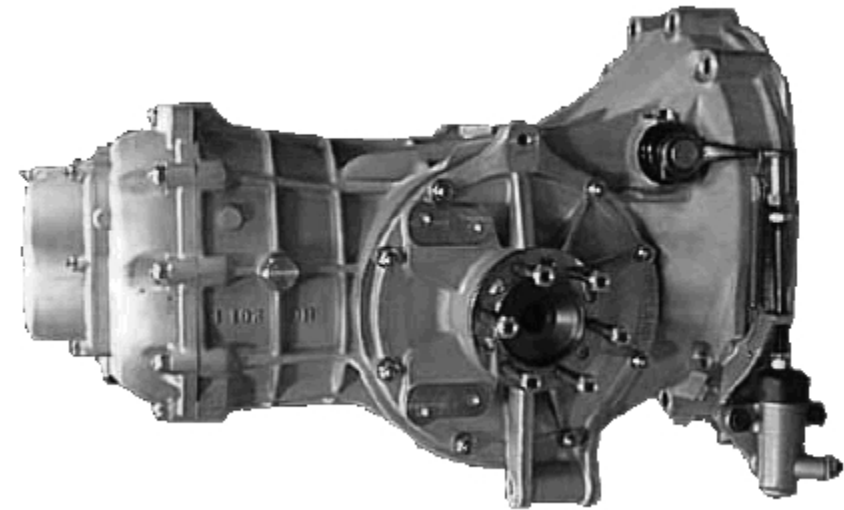

- 1. Med ett extra kugghjul före diffen*
- X. Monterade växellådan uppochned*
- 2. Bytte rotationsriktning på motorn*



Var fanns fönstret
som han klev ut
Genom?

1. *Arboga*
- X. *Malmköping*
2. *Åkers Styckebruk*





9

Denna Grand Prix-racer från 1951 var höggradigt beroende av högt laddtryck. Vem tillhandahöll detta?

- 1. *Roots*
- X. *Wilson*
- 2. *Rolls Royce*





10

De här fordonen drevs av 8-cylindriga motorer med samma ursprung. Vilket Märke?

1. *Bugatti*
- X. *Hispano-Suiza*
2. *Maybach*

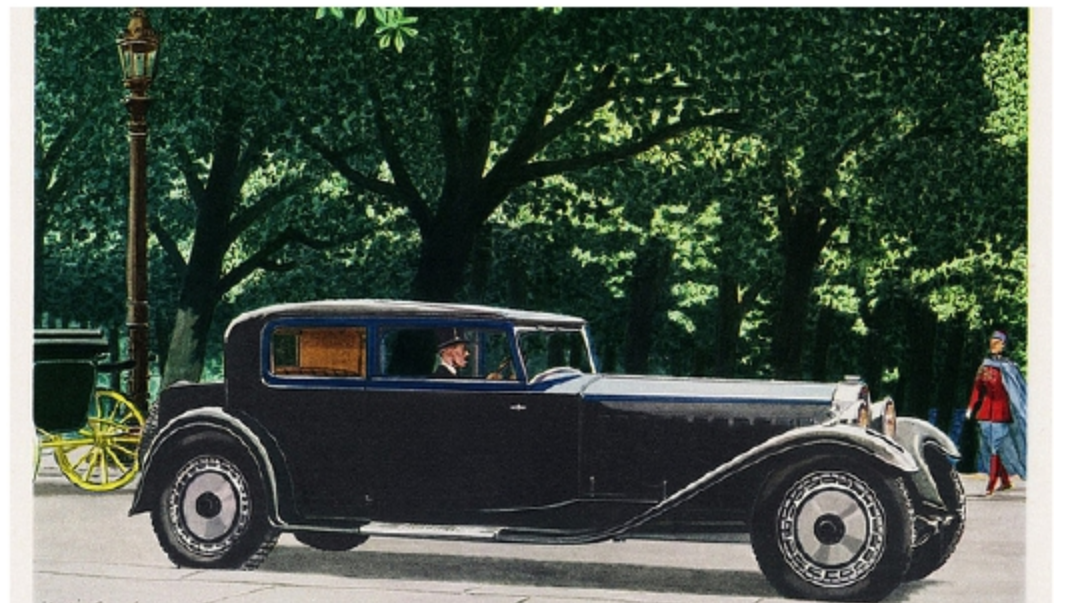

Föraren klarade sig
mycket bättre än
bilen... På vilken
bana inträffade
Missödet?

1. *Hockenheim*
- X. *Nürburgring*
2. *Avus*





12

**V4 med 32 ventiler,
8 vevstakar, 8 tändstift
och unika kolvar.
Vem byggde den?**

1. *Moto Guzzi*
- X. *Honda*
2. *Ducati*



Vilken typ av motor hade denna Trotjänare?

1. *Dieselmotor*
- X. *Hesselmanmotor*
2. *Tändkulemotor*



Vem lanserade
denna avancerade
Formelbil?

1. *Lancia*
- X. *Maserati*
2. *Ferrari*

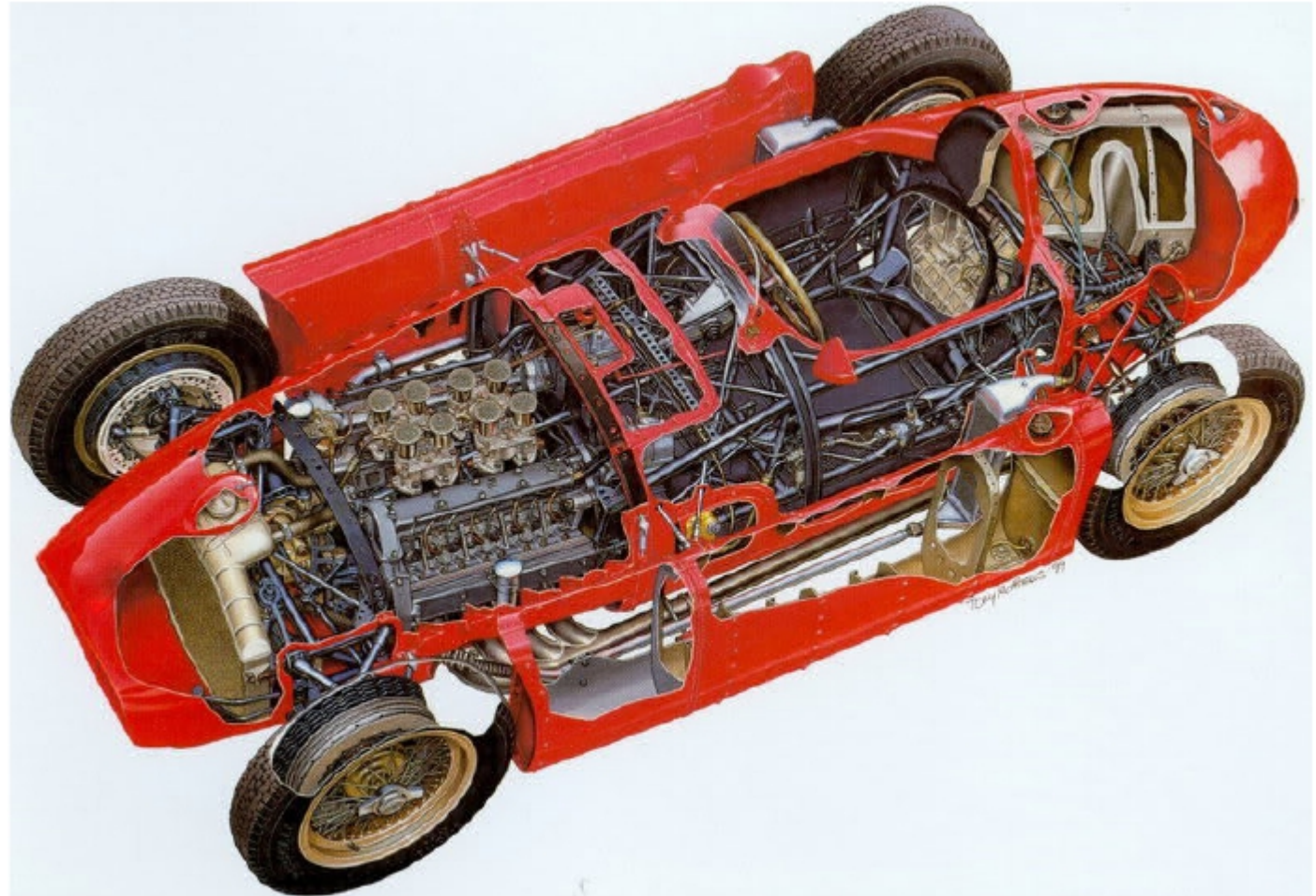



Denne man hade fast anställning i Sverige 1985-95.

Vem sköter idag detta arbete?



15

1



X



2



Vilken biltillverkare har presenterat denna idé, en hybrid med *pneumatisk* Energilagring?

1. *Honda*
- X. *Peugeot*
2. *Volkswagen*

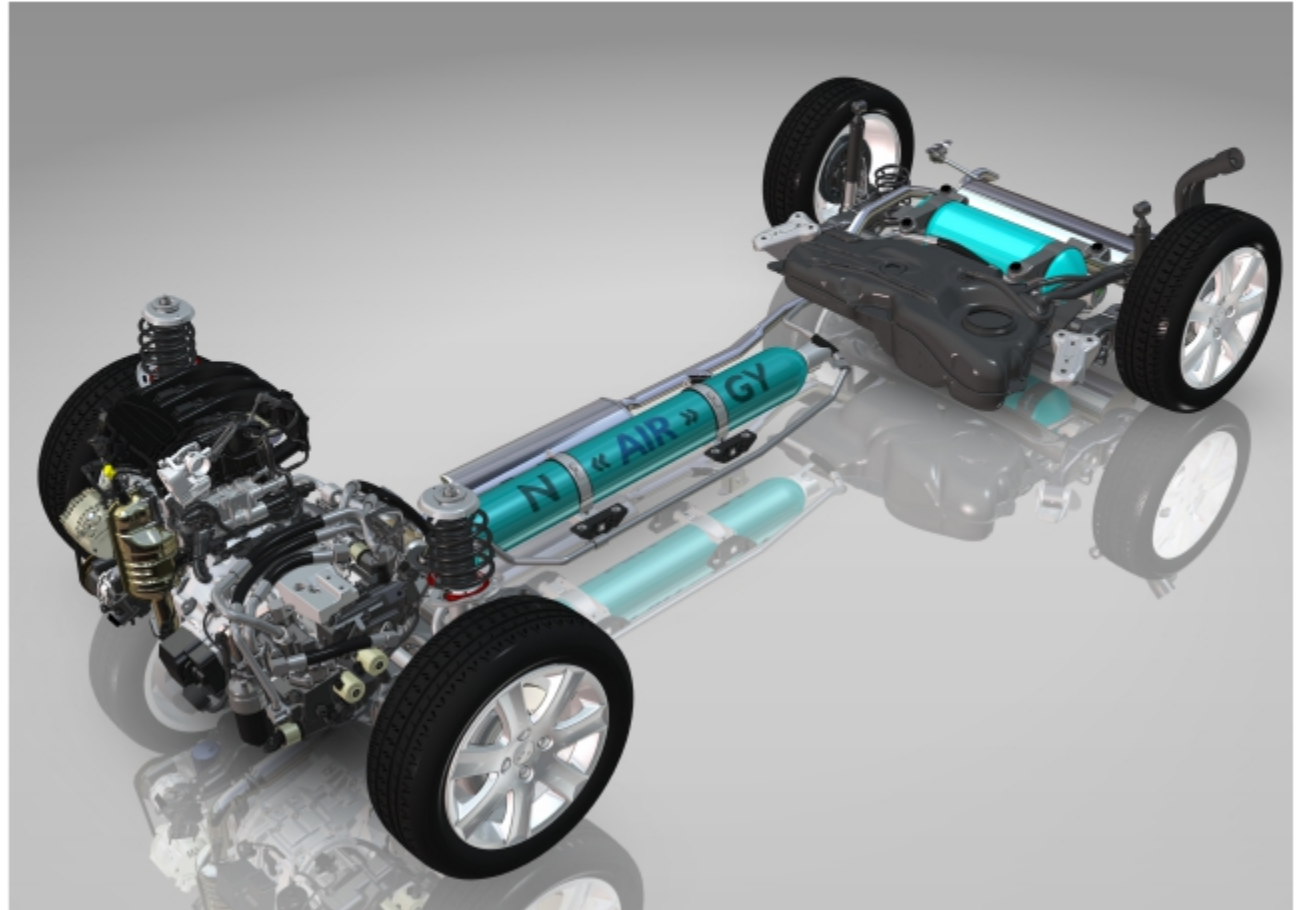

Vem begärde utträde ur en klubb, som han just blivit antagen till, med motiveringen:

"En förening som har så dåligt omdöme att man accepterar mig som medlem, den vill inte jag tillhöra!"

1.



X.



2.

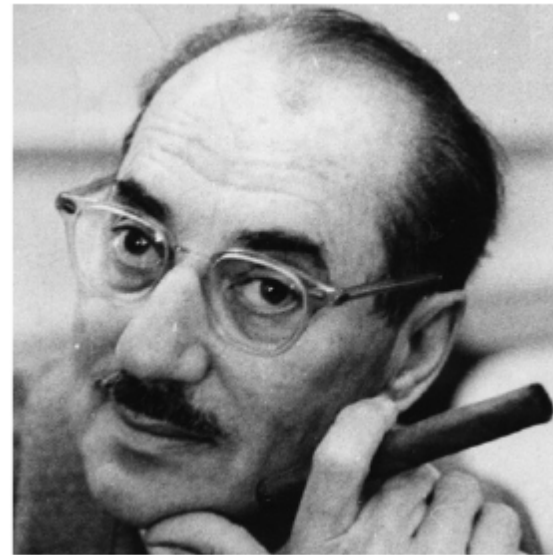

Vad föreställer bilden?

1. *Franciskanerordens heliga symbol*

2. *Australiensisk proffs-Frisbee*

2. *Kopplingslamell för tävlingsbruk*



Av den här klassiska banan återstår idag bara rester. När invigdes den?

1. 1907
- X. 1917
2. 1927



Legendarisk stallchef i
Formel 1, men han hade en
annan verksamhet också.
Vilken?

1. *Teimportör*
- X. *Öltillverkare*
2. *Virkeshandlare*

